

# TMC1175A/TMC1275

## Video A/D Converter

**8 bit, 50 Msp**

### Features

- 8-Bit resolution
- 50 Msp conversion rate
- Low power: 100mW at 20 Msp
- Integral track/hold
- Integral and differential linearity error 0.5 LSB
- Single or dual +5 Volt supplies
- Differential phase 0.5 degree
- Differential gain 1.5%
- Three-state TTL/CMOS-compatible outputs
- Low cost

### Applications

- Video digitizing
- VGA and CCD digitizing
- LCD projection panels
- Image scanners
- Personal computer video boards
- Multimedia systems
- Low cost, high speed data conversion

### Description

The TMC1175A/1275 analog-to-digital (A/D) converter employs a two-step flash architecture to convert analog signals into 8-bit digital words at sample rates of up to 50 Msp (Megasamples per second). An integral Track/Hold circuit delivers excellent performance on signals with full-scale frequency components up to 12 MHz. Innovative architecture and submicron CMOS technology limit typical power dissipation to 100 mW.

Power may be derived from either single or dual +5V supplies. Internal voltage reference resistors allow self-bias operation. Input capacitance is very low, simplifying or eliminating input driving amplifiers. All digital three-state outputs are TTL- and CMOS-compatible.

The TMC1175A and TMC1275 share their core architectures; the TMC1275 adds two overrange outputs that indicate when the analog input signal is beyond the conversion range.

The TMC1175A/1275 is available in 24-pin plastic DIP, 24-lead plastic SOIC, and 28-lead J-lead PLCC packages. Performance specifications are guaranteed from -20°C to 75°C.

### Block Diagram

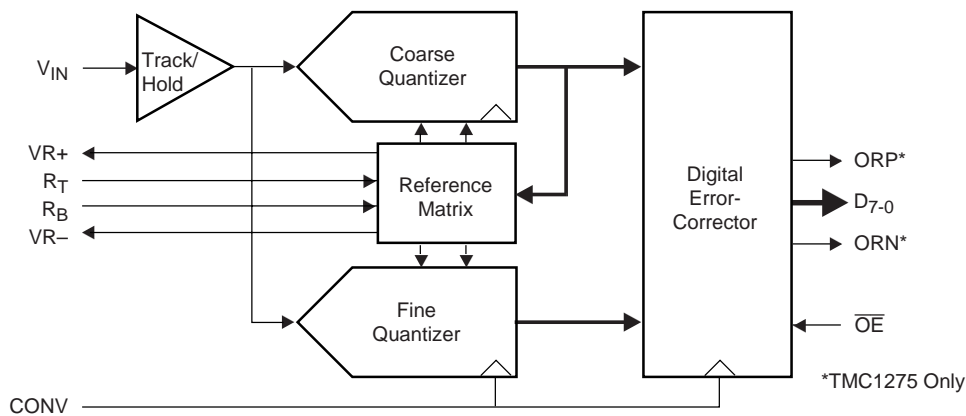

## Functional Description

The TMC1175A/1275 8-bit A/D converter uses a two-step architecture to perform analog-to-digital conversion at rates up to 50 Msps. The input signal is held in an integral track/hold stage during the conversion process. Operation is pipelined, with one input sample taken and one output word provided for each CONVert cycle.

The first step in the conversion process is a coarse 4-bit quantization. This determines the range of the subsequent fine 4-bit quantization step. To eliminate spurious codes, the fine 4-bit A/D quantizer output is gray-coded and converted to binary before it is combined with the coarse result to form a complete 8-bit result.

### Analog Input and Voltage References

The TMC1175A/1275 converts analog signals in the range  $R_B$  to  $R_T$  into digital data. Input signals outside that range produce “saturated” 00h or FFh output codes. The device will not be damaged by signals within the range AGND to  $V_{DDA}$ .

The A/D converter input range is very flexible and extends from the +5 Volt power supply to ground. The nominal input range is 2 Volts, from 0.6V to 2.6V. The circuit is characterized and performance is specified over that range. However, the part will work well with a full-scale range from 1.0V to 5.0V. A reduced input range may simplify analog signal conditioning circuitry, at the expense of additional noise sensitivity and some reduced differential linearity performance. Similarly, increasing the range can improve differential linearity, but puts a greater burden on the input signal conditioning circuitry.

In many applications, external voltage reference sources are connected to the  $R_T$  and  $R_B$  pins.  $R_B$  can be grounded. Gain and offset errors are directly related to the accuracy and stability of the applied reference voltages.

Two reference pull-up and pull-down resistors connected to  $VR+$  and  $VR-$  are provided internally for operation without external voltage reference circuitry (Figure 1). The reference voltages applied to  $R_T$  and  $R_B$  may be generated by connecting  $VR+$  to  $R_T$  and  $VR-$  to  $R_B$ . The power supply voltage is divided by the on-chip resistors to bias the  $R_T$  and  $R_B$  points. This sets-up the converter for operation in its nominal range from 0.6V to 2.6V.

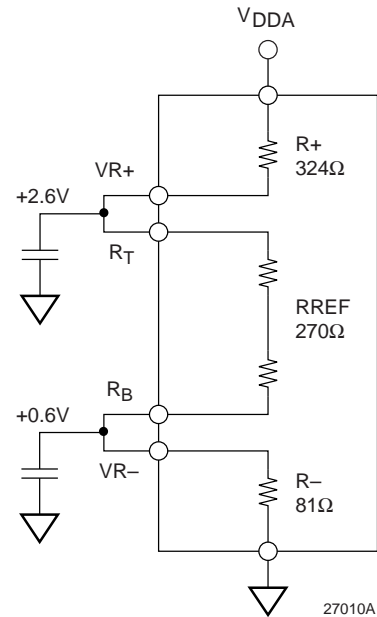

Figure 1. Reference Resistors

With  $V_{DDA}$  at 5.0V, connecting  $VR+$  to  $R_T$  and grounding  $R_B$  will provide an input range from 0.0V to 2.27V, while connecting  $R_T$  to  $V_{DDA}$  and  $R_B$  to  $VR-$  produces a full scale range of 3.85V referenced to  $V_{DDA}$ . External resistors may also be employed to provide arbitrary reference voltages, but they will not match the temperature coefficient of the on-chip resistors as well as  $R+$  and  $R-$ , and will cause the converter transfer function to vary with temperature.

With this implementation, errors in the power supply voltage end up on the conversion data output.

Because a two-step conversion process is employed, it is important that the references remain stable during the ENTIRE conversion process (two clock cycles). The reference voltage can then be changed, but any conversion in progress during a reference change is invalid.

**Table 1. Output Coding**

Input Voltage	ORP <sup>2</sup>	ORN <sup>2</sup>	Output
$R_T + 1 \text{ LSB}$	1	0	FF
$R_T$	0	0	FF
$R_T - 1 \text{ LSB}$	0	0	FE
...	...	...	...
$R_B + 128 \text{ LSB}$	0	0	80
$R_B + 127 \text{ LSB}$	0	0	7F
...	...	...	...
$R_B + 1 \text{ LSB}$	0	0	01
$R_B$	0	0	00
$R_B - 1 \text{ LSB}$	0	1	00

**Notes:**

1.  $\text{LSB} = (R_T - R_B) / 255$
2. TMC1275 Only

**Digital Inputs and Outputs**

Sampling of the applied input signal takes place on the **falling** edge of the CONV signal (Figure 2). The output word is delayed by 2 1/2 CONV cycles. It is then available after the **rising** edge of CONV. The previous data on the output remain valid for  $t_{HO}$  (Output Hold Time), satisfying any hold time requirement of the receiving circuit. The new data become valid  $t_{DO}$  (Output Delay Time) after this rising edge of CONV.

Whenever the analog input signal is sampled and found to be at a level beyond the A/D conversion range, an Overrange output of the TMC1275 will go HIGH. If the input is more positive (by at least one LSB) than the positive end of the range, ORP will go HIGH and D7-0 will be FFh. If the input is more negative (by at least one LSB) than the negative end of the range, ORN will go HIGH and D7-0 will be 00h.

The outputs of the TMC1175A/1275 are CMOS- and TTL-compatible, and are capable of driving four low-power Schottky TTL (54/74LS) loads. An Output Enable control,  $\overline{OE}$ , places the outputs in a high-impedance state when HIGH. The outputs are enabled when  $\overline{OE}$  is LOW.

**Power and Ground**

To minimize noise injection into the analog section,  $V_{DDA}$  may be connected to a separate regulated +5 volt supply.  $V_{DDD}$  may be connected to a digital supply. Power up sequence is immaterial. Latch-up will not occur.

AGND and DGND pins should be connected to a common ground plane. For optimum performance treat analog and digital PWB traces as transmission lines. Route analog connections cleanly to the TMC1175A/1275. Segregate digital connections and if necessary terminate clocks to eliminate ringing. Prevent digital return currents from flowing across analog input sections of the TMC1175A/1275.

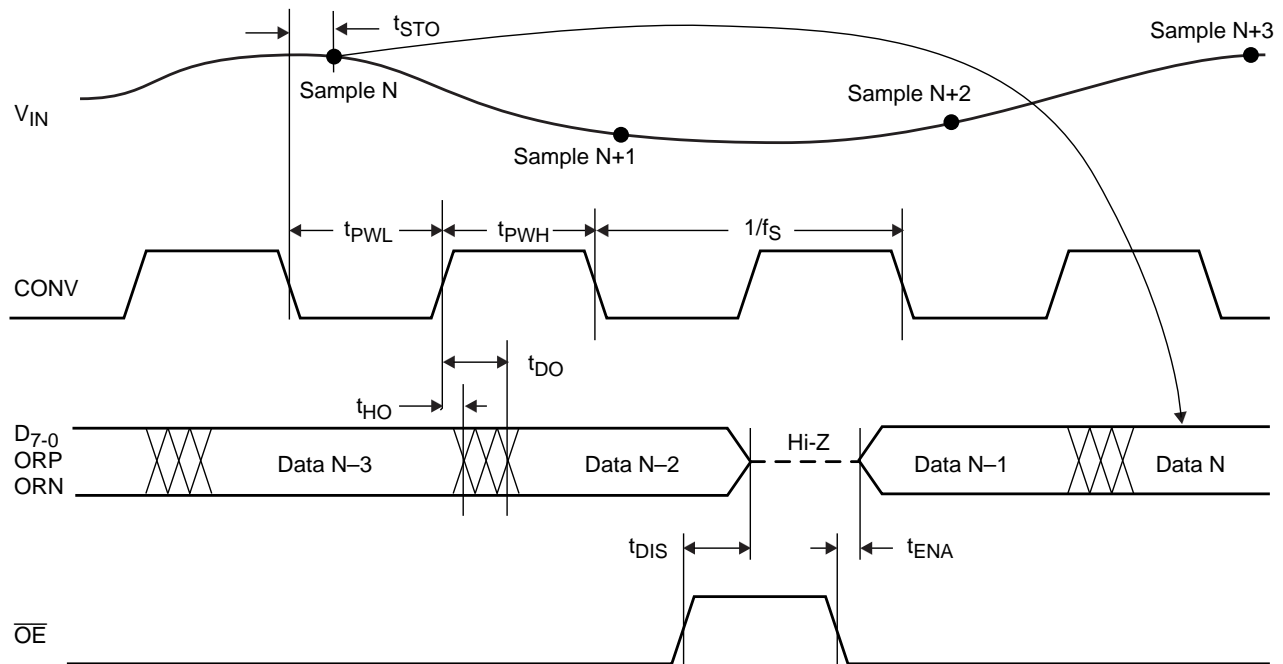

24455A

**Figure 2. Conversion Timing**

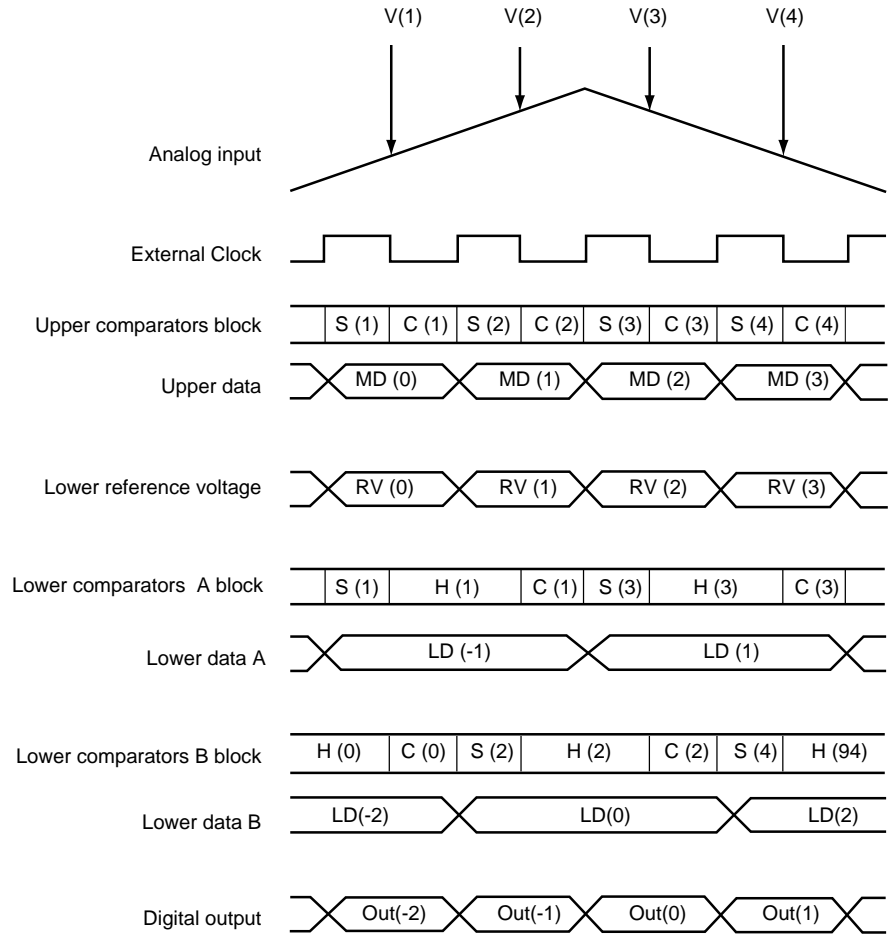

65-7568

Figure 3. Internal Timing

## Pin Assignments

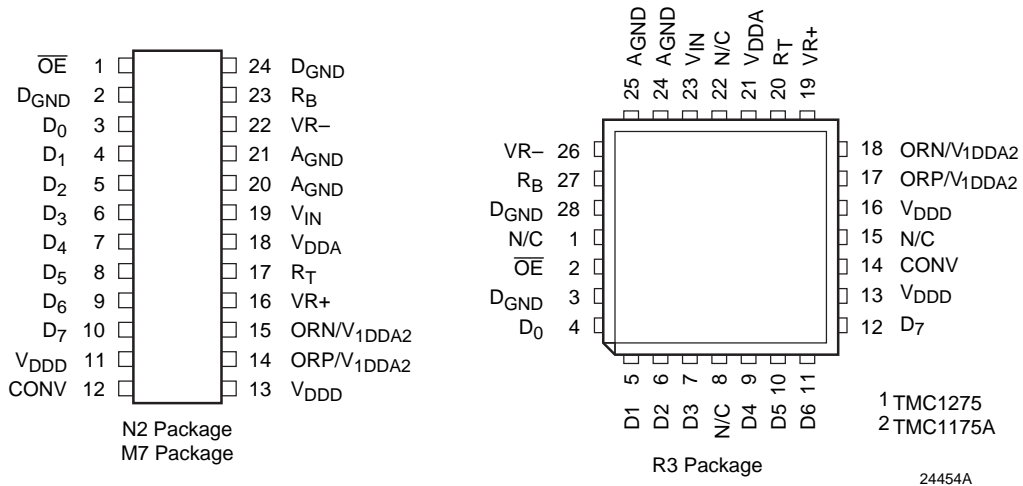

## Pin Descriptions

Pin Name	Pin Number		Pin Type	Pin Function Description
	N2, M7	R3		
<b>Inputs</b>				
V <sub>IN</sub>	19	23	RT – RB	<b>Analog Input.</b> The input voltage conversion range lies between the voltages applied to the RT and RB pins.
R <sub>T</sub>	17	20	2.6V	<b>Reference Voltage Top Input.</b> R <sub>T</sub> is the top input to the reference resistor ladder. A DC voltage applied to R <sub>T</sub> defines the positive end of the V <sub>IN</sub> conversion range.
R <sub>B</sub>	23	27	0.6V	<b>Reference Voltage Bottom Input.</b> R <sub>B</sub> is the bottom input to the reference resistor ladder. A DC voltage applied to R <sub>B</sub> defines the negative end of the V <sub>IN</sub> conversion range.
VR+	16	19		<b>Reference Voltage Top Source.</b> VR+ is the internal pull-up reference resistor for self-bias operations.
VR–	22	26		<b>Reference Voltage Bottom Source.</b> VR– is the internal pull-down reference resistor for self-bias operations.
OE	1	2	CMOS	<b>Output Enable.</b> (CMOS-compatible) When LOW, D7-0 are enabled. When HIGH, D7-0 are in a high-impedance state.
CONV	12	14	CMOS	<b>Convert (Clock) Input.</b> (CMOS-compatible) V <sub>IN</sub> is sampled on the falling edge of CONV.
<b>Outputs</b>				
D7-0	10–3	12–9, 7–4	CMOS/ TTL	<b>Data Outputs (D7 = MSB).</b> Eight-bit CMOS- and TTL-compatible digital outputs. Data is output following the rising edge of CONV.
ORP <sup>1</sup>	14 <sup>1</sup>	17 <sup>1</sup>	CMOS/ TTL	<b>OverRange Positive Output.</b> When HIGH, ORP indicates that the analog input voltage is at least one LSB higher than the voltage that produces output code FFh. ORP is synchronous with D7-0.
ORN <sup>1</sup>	15 <sup>1</sup>	18 <sup>1</sup>	CMOS/ TTL	<b>OverRange Negative Output.</b> When HIGH, ORN indicates that the analog input voltage is at least one LSB lower than the voltage that produces output code 00h. ORN is synchronous with D7-0.
<b>Power</b>				
V <sub>DDA</sub>	14 <sup>2</sup> , 15 <sup>2</sup> , 18	17 <sup>2</sup> , 18 <sup>2</sup> , 21	+5V	<b>Analog Supply Voltage.</b> Independent +5 volt power connection to analog comparator circuits.
V <sub>DDD</sub>	11, 13	13, 16	+5V	<b>Digital Supply Voltage.</b> Independent +5 volt power connection to digital error correction and output drivers.
AGND	20, 21	24, 25	0.0V	<b>Analog Ground.</b> Connect to the system analog ground plane.
DGND	2, 24	3, 28	0.0V	<b>Digital Ground.</b> Connect to the system analog ground plane.
<b>No Connect</b>				
N/C		1, 8, 15, 22	open	Not Connected.

### Notes:

1. TMC1275 Only.
2. TMC1175A Only.

## Bandwidth Specification Notes

The specification for bandwidth of an A/D converter is somewhat different from the normal frequency-response specification used in amplifiers and filters. An understanding of the differences will help in selecting converters properly for particular applications.

A/D conversion comprises two distinct processes: *sampling* and *quantizing*. *Sampling* is “grabbing” a snapshot of the input signal and holding it steady for quantizing. The *quantizing* process is approximating the analog input, which may be any value within the conversion range, with its nearest numerical value. While sampling is a high-frequency process, quantizing operates on a dc signal, held steady by the track/hold circuit. Therefore, the sampling process is what relates to the dynamic characteristics of the converter.

Sampling involves an *aperture time*, the time during which the track/hold is trying to capture the input signal and settle on a dc value to hold. It is analogous to the shutter speed of a camera: the shorter the aperture (or faster the shutter) the less the signal will be blurred, and the less uncertainty there will be in the quantized value.

For example, a 10 MHz sinewave with a 1V peak amplitude (2Vp-p) has a maximum slew rate of  $2\pi fA$  at zero crossing, or  $62.8\text{V}/\mu\text{s}$ . With an 8-bit A/D converter,  $q$  (the quantization step size) =  $2\text{V}/255 = 7.8\text{mV}$ . The input signal will slew one

LSB in 124ps. To limit the error (and noise) contribution due to *aperture effects* to  $1/2\text{LSB}$ , the aperture must be shorter than 62ps.

This is the primary reason that the signal to noise ratio drops off as full scale frequency increases. Note, also, that the slew rate is directly proportional to signal amplitude. A. A/Ds will handle lower-amplitude signals of higher bandwidth.

All this is of particular interest in applications such as digitizing analog VGA RGB signals, or the output of a CCD imaging chip. These data are effectively pre-sampled: there is a period of rapid slewing from one pixel value to another, followed by a relatively stable dc level before the signal slews to the next pixel value. The goal is, of course, to sample on these pixel values, not on the slewing between pixels. During the aperture time, the A/D sees essentially a dc signal, and classic bandwidth considerations are not important. As long as the input circuit can slew and settle to the new value in the prescribed period, an accurate conversion will be made.

The TMC1175A/1275 is capable of slewing a full 2V and settling between samples taken as little as 25ns apart, making it ideal for digitizing analog VGA and CCD outputs.

## Equivalent Circuits and Threshold Level

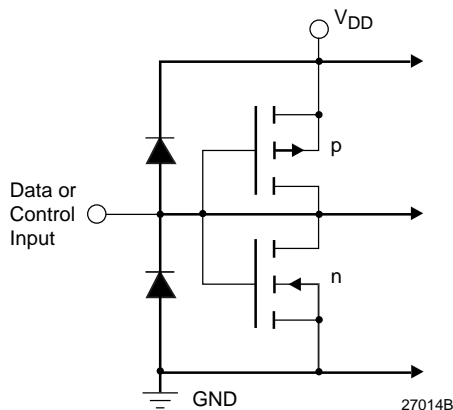

Figure 4. Equivalent Digital Input Circuit

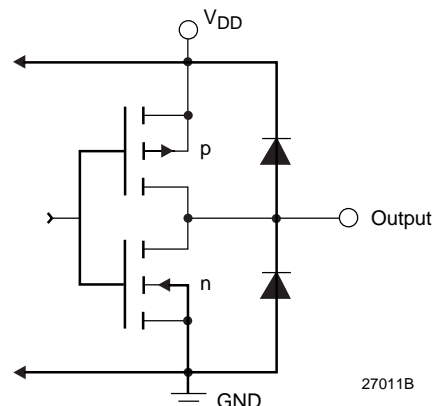

Figure 5. Equivalent Digital Output Circuit

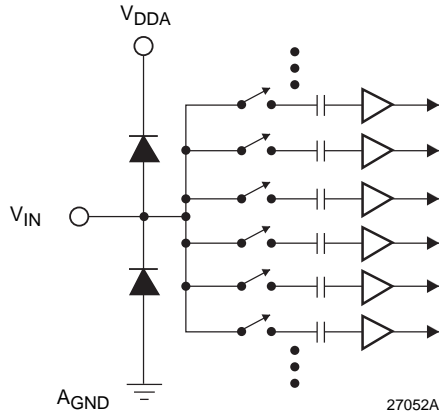

Figure 6. Equivalent Analog Input Circuit

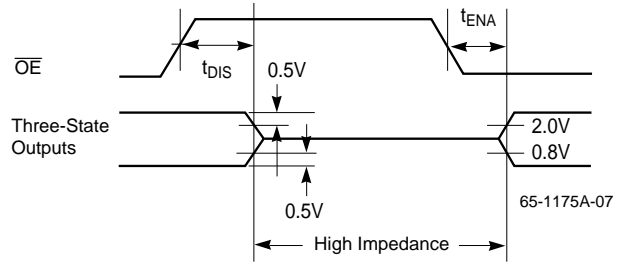

Figure 7. Threshold Levels for Three-State Measurements

### Absolute Maximum Ratings

(beyond which the device may be damaged)<sup>1</sup>

Parameter	Conditions	Min	Typ	Max	Unit
<b>Power Supply Voltages</b>					
V <sub>D</sub> DA	Measured to AGND	-0.5		7.0	V
V <sub>D</sub> DD	Measured to DGND	-0.5		7.0	
V <sub>D</sub> DA	Measured to V <sub>D</sub> DD	-0.5		0.5	V
AGND	Measured to DGND	-0.5		0.5	
<b>Digital Inputs</b>					
Applied Voltage <sup>2</sup>	Measured to DGND	-0.5		V <sub>D</sub> DD + 0.5	V
Forced Current <sup>3,4</sup>		-10.0		10.0	mA
<b>Analog Inputs</b>					
Applied Voltage <sup>2</sup>	Measured to AGND	-0.5		V <sub>D</sub> DA + 0.5	V
Forced Current <sup>3,4</sup>		-10.0		10.0	mA
<b>Outputs</b>					
Applied Voltage <sup>2</sup>	Measured to DGND	-0.5		V <sub>D</sub> DD + 0.5	V
Forced Current <sup>3,4</sup>		-6.0		6.0	mA
Short Circuit Duration	Single output in HIGH state to ground			1	sec
<b>Temperature</b>					
Operating, Ambient		-20		110	°C
Junction				150	°C
Storage		-65		150	°C
Lead Soldering	10 seconds			300	°C
Vapor Phase Soldering	1 minute			220	°C

**Notes:**

- Functional operation under any of these conditions is NOT implied. Performance and reliability are guaranteed only if operating conditions are not exceeded.
- Applied voltage must be current limited to specified range.
- Forcing voltage must be limited to specified range.
- Current is specified as conventional current flowing into the device

## Operating Conditions

Parameter			Min	Nom	Max	Units
VDDD	Digital Power Supply Voltage		4.75	5.0	5.25	V
VDDA	Analog Power Supply Voltage		4.75	5.0	5.25	V
AGND	Analog Ground (Measured to DGND)		-0.1	0	0.1	V
fS	Conversion Rate	TMC1175A/1275-20			20	MSPS
		TMC1175A/1275-30			30	MSPS
		TMC1175A/1275-40			40	MSPS
		TMC1175A/1275-50			50	MSPS
tPWH	CONV Pulsewidth, HIGH	TMC1175A/1275-20	15			ns
		TMC1175A/1275-30	13			ns
		TMC1175A/1275-40	12			ns
		TMC1175A/1275-50	9			ns
tPWL	CONV Pulsewidth, LOW	TMC1175A/1275-20	15			ns
		TMC1175A/1275-30	12			ns
		TMC1175A/1275-40	12			ns
		TMC1175A/1275-50	9			ns
VRT	Reference Voltage, Top		2.0	2.6	VDDA	V
VRB	Reference Voltage, Bottom		0	0.6	3.0	V
VRT-VRB	Reference Voltage Differential		1.0		5.0	V
VIN	Analog Input Range		VRB		VRT	V
VIH	Input Voltage, Logic HIGH		0.7 x VDDD		VDDD	V
VIL	Input Voltage, Logic LOW		GND		0.3 x VDDD	V
IOH	Output Current, Logic HIGH				-4.0	mA
IOL	Output Current, Logic LOW				4.0	mA
TA	Ambient Temperature, Still Air		-20		75	°C

## Electrical Characteristics

Parameter		Conditions	Min	Typ <sup>1</sup>	Max	Units	
IDD	Power Supply Current <sup>1</sup>	VDDD = VDDA = Max, CLOAD = 35pF					
		fS = 20MSPS		20	30	mA	
		fS = 30MSPS			25	35	mA
		fS = 40MSPS			30	40	mA
		fS = 50MSPS			35	48	mA
IDDQ	Power Supply Current, Quiescent	VDDD = VDDA = Max					
		CONV = LOW		7	18	mA	
		CONV = HIGH		10	20	mA	



**Electrical Characteristics** (continued)

Parameter		Conditions	Min	Typ <sup>1</sup>	Max	Units	
PD	Total Power Dissipation	V <sub>DDD</sub> = V <sub>VDDA</sub> = Max, C <sub>LOAD</sub> = 35pF					
		f <sub>S</sub> = 20Msps		100	160	mW	
		f <sub>S</sub> = 30Msps			125	185	mW
		f <sub>S</sub> = 40Msps			150	210	mW
		f <sub>S</sub> = 50Msps			185	250	mW
CAI	Input Capacitance, Analog	CONV = LOW		4		pF	
		CONV = HIGH		12		pF	
RIN	Input Resistance		500	1000		kΩ	
ICB	Input Current, Analog				±1	μA	
RREF	Reference Resistance		200	270	340	Ω	
I <sub>IH</sub>	Input Current, HIGH	V <sub>DDD</sub> = Max, V <sub>IN</sub> = V <sub>DDD</sub>			±5	μA	
I <sub>IL</sub>	Input Current, LOW	V <sub>DDD</sub> = Max, V <sub>IN</sub> = 0V			±5	μA	
IOZH	Hi-Z Output Leakage	V <sub>DDD</sub> = Max, V <sub>IN</sub> = V <sub>DDD</sub>			±5	μA	
IOZL	Hi-Z Output Leakage	V <sub>DDD</sub> = Max, V <sub>IN</sub> = 0V			±5	μA	
IOS	Short-Circuit Current				-30	mA	
VOH	Output Voltage, HIGH	I <sub>OH</sub> = -100μA	V <sub>DDD</sub> -0.3			V	
		I <sub>OH</sub> = -2.5mA	3.5			V	
		I <sub>OH</sub> = Max	2.4			V	
VOL	Output Voltage, LOW	I <sub>OL</sub> = Max			0.4	V	
CDI	Digital Input Capacitance			4	10	pF	
CDO	Digital Output Capacitance			10		pF	

**Note:**

1. Typical values with V<sub>DDD</sub> = V<sub>VDDA</sub> = Nom and T<sub>A</sub> = Nom, Minimum/Maximum values with V<sub>DDD</sub> = V<sub>VDDA</sub> = Max and T<sub>A</sub> = Min.

**Switching Characteristics**

Parameter		Conditions	Min	Typ	Max	Units
t <sub>STO</sub>	Sampling Time Offset		2	5	8	ns
t <sub>HO</sub>	Output Hold Time	C <sub>LOAD</sub> = 15pF	5			ns
t <sub>DO</sub>	Output Delay Time	C <sub>LOAD</sub> = 15pF			20	ns
t <sub>ENA</sub>	Output Enable Time				27	ns
t <sub>DIS</sub>	Output Disable Time				42	ns

## System Performance Characteristics

Parameter		Conditions	Min	Typ <sup>1</sup>	Max	Units	
ELI	Integral Linearity Error, Independent	$V_{RT} = 2.6V$ $V_{RB} = 0.6V$		$\pm 0.5$	$\pm 1$	LSB	
ELD	Differential Linearity Error	$V_{RT} = 2.6V$ $V_{RB} = 0.6V$		$\pm 0.3$	$\pm 1$	LSB	
BW	Bandwidth <sup>2</sup>	TMC1175A/1275-20 TMC1175A/1275-30 TMC1175A/1275-40 TMC1175A/1275-50			10 12 12 12	MHz MHz MHz MHz	
EAP	Aperture Error			30		ps	
EOT	Offset Voltage, Top	$RT - V_{IN}$ for most positive code transition	-8	-25	-42	mV	
EOB	Offset Voltage, Bottom	$RB - V_{IN}$ for most negative code transition	30	40	60	mV	
dg	Differential Gain	$f_S = 14.3\text{Msps}$ NTSC 40 IRE Mod Ramp $V_{DDA} = +5.0V$ , $T_A = 25^\circ\text{C}$ $V_{RT} = 2.6V$ , $V_{RB} = 0.6V$		1.5	2.7	%	
dp	Differential Phase	$f_S = 14.3\text{Msps}$ NTSC 40 IRE Mod Ramp $V_{DDA} = +5.0V$ , $T_A = 25^\circ\text{C}$ $V_{RT} = 2.6V$ , $V_{RB} = 0.6V$		0.5	1.0	deg	
SNR <sup>3</sup>	Signal-to-Noise Ratio	$f_S = 20\text{Msps}$ , $V_{RT} = 2.6V$ , $V_{RB} = 0.6V$					
		$f_{IN} = 1.24\text{MHz}$	44	48		dB	
		$f_{IN} = 2.48\text{MHz}$	43	47		dB	
		$f_{IN} = 6.98\text{MHz}$	41	45		dB	
		$f_{IN} = 10.0\text{MHz}$	37	42		dB	
		$f_S = 30\text{Msps}$ , $V_{RT} = 2.6V$ , $V_{RB} = 0.6V$					
		$f_{IN} = 1.24\text{MHz}$	42	47		dB	
		$f_{IN} = 2.48\text{MHz}$	40	45		dB	
		$f_{IN} = 6.98\text{MHz}$	38	43		dB	
		$f_{IN} = 10.0\text{MHz}$	33	39		dB	
		$f_{IN} = 12.0\text{MHz}$	30	37		dB	
		$f_S = 40\text{Msps}$ , $V_{RT} = 2.6V$ , $V_{RB} = 0.6V$					
$f_{IN} = 1.24\text{MHz}$	40	45		dB			
$f_{IN} = 2.48\text{MHz}$	38	43		dB			
$f_{IN} = 6.98\text{MHz}$	36	41		dB			
$f_{IN} = 10.0\text{MHz}$	34	38		dB			
$f_{IN} = 12.0\text{MHz}$	32	36		dB			
$f_S = 50\text{Msps}$ , $V_{RT} = 2.6V$ , $V_{RB} = 0.6V$							
$f_{IN} = 10.0\text{MHz}$	30			dB			

**System Performance Characteristics** (continued)

Parameter	Conditions	Min	Typ <sup>1</sup>	Max	Units	
SFDR <sup>4</sup> Spurious-Free Dynamic Range	$f_S = 20\text{Msps}$ , $V_{RT} = 2.6\text{V}$ , $V_{RB} = 0.6\text{V}$ $f_{IN} = 1.24\text{MHz}$	46	52		dB	
		$f_{IN} = 2.48\text{MHz}$	44	51		dB
			41	45		dB
		$f_{IN} = 10.0\text{MHz}$	38	43		dB
	$f_S = 30\text{Msps}$ , $V_{RT} = 2.6\text{V}$ , $V_{RB} = 0.6\text{V}$ $f_{IN} = 1.24\text{MHz}$	42	49		dB	
		$f_{IN} = 2.48\text{MHz}$	40	45		dB
			37	41		dB
		$f_{IN} = 10.0\text{MHz}$	35	40		dB
		$f_{IN} = 12.0\text{MHz}$	34	39		dB
	$f_S = 40\text{Msps}$ , $V_{RT} = 2.6\text{V}$ , $V_{RB} = 0.6\text{V}$ $f_{IN} = 1.24\text{MHz}$	40	44		dB	
		$f_{IN} = 2.48\text{MHz}$	39	43		dB
			38	41		dB
		$f_{IN} = 10.0\text{MHz}$	36	40		dB
		$f_{IN} = 12.0\text{MHz}$	36	39		dB
	$f_S = 50\text{Msps}$ , $V_{RT} = 2.6\text{V}$ , $V_{RB} = 0.6\text{V}$ $f_{IN} = 10.0\text{MHz}$	33			dB	

**Notes:**

1. Values shown in Typ column are typical for  $V_{DD} = V_{DDA} = +5\text{V}$  and  $T_A = 25^\circ\text{C}$ .
2. Bandwidth is the frequency up to which a full-scale sine wave can be digitized without spurious codes.
3. SNR values do not include the harmonics of the fundamental frequency.
4. SFDR is the ratio in dB of fundamental amplitude to the harmonic with the highest amplitude.

## Typical Performance Characteristics

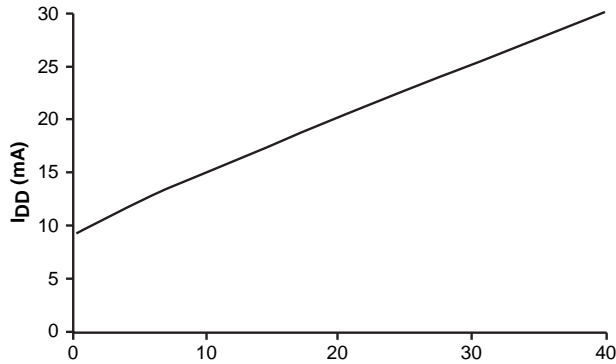

Figure 8. Typical  $I_{DD}$  vs  $f_s$

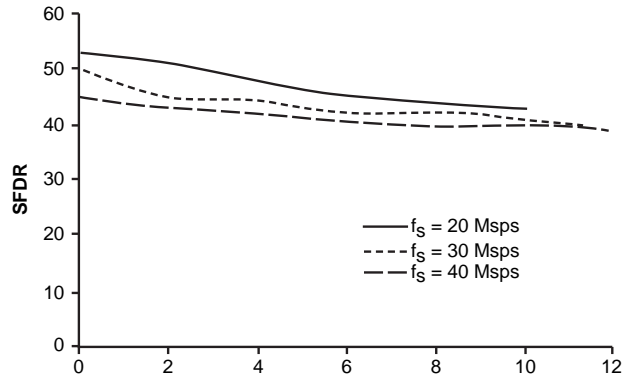

Figure 9. Typical SFDR vs  $f_{IN}$  and  $f_s$

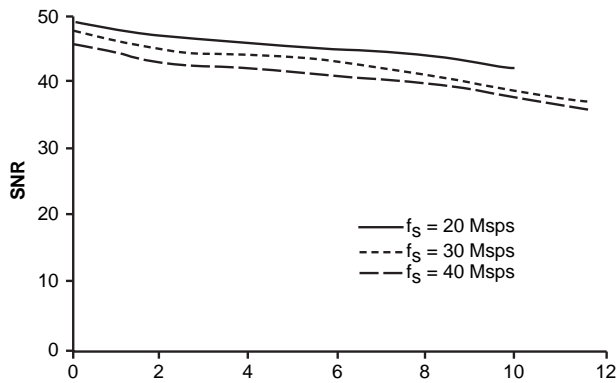

Figure 10. Typical SNR vs  $f_{IN}$  and  $f_s$

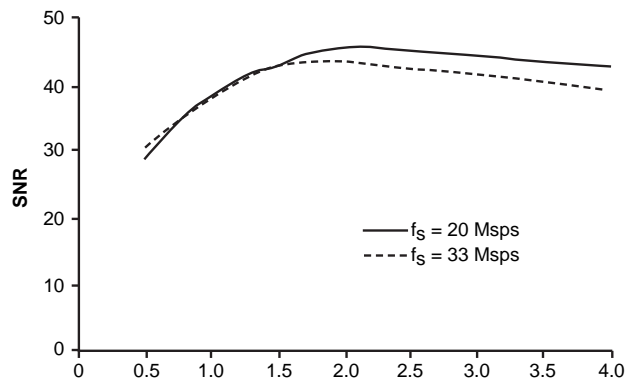

Figure 11. Typical SNR vs Full Scale Input Range

## Applications Discussion

The circuit in Figure 12 employs a band-gap reference to generate a variable  $R_T$  reference voltages for the TMC1175A/1275 as well as a bias voltage to offset the wideband input amplifier to mid-range. An "offset adjust" is also shown for varying the mid-range voltage level. The operational amplifier in the reference circuitry is a standard 741-type.

The voltage reference at  $R_T$  can be adjusted from 0.0 to 2.4 volts while  $R_B$  is grounded. Diodes are used to restrict the wideband amplifier output to between -0.7V and  $V_{DD} + 0.7V$ . Diode protection is good practice to limit the analog input voltage at  $V_{IN}$  to the safe operating range.

The circuit in Figure 13 shows self-bias of  $R_T$  and  $R_B$  by connection to  $VR+$  and  $VR-$ . This sets up a 0.6 to 2.6 Volt input range for  $V_{IN}$ . The input range is susceptible to power supply variation since the voltages on  $R_T$  and  $R_B$  are directly derived from  $V_{DDA}$ . The video input is AC-coupled and biased at a adjustable midpoint of the A/D input range. This circuit offers the advantage of minimum support circuitry for the most cost-sensitive applications.

In Figure 14, an external band-gap reference sets  $R_T$  to +1.2 Volts while  $R_B$  is grounded. The internal pull-up resistor,  $R+$ , provides the bias current for the band-gap reference. The A/D converter input is biased to the mid-point of the input range.

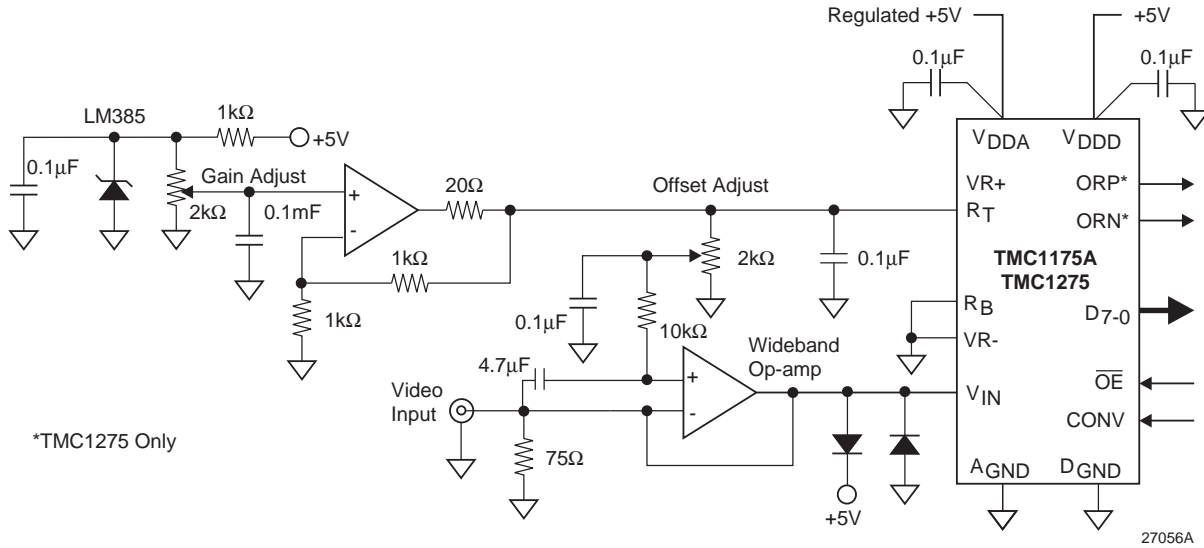

Figure 12. Typical Interface Circuit - High Performance

**Grounding**

The TMC1175A/1275 has separate analog and digital circuits. To keep digital system noise from the A/D converter, it is recommended that power supply voltages (VDDD and VDDA) originate from separate sources with VDDA regulated, and that ground connections (DGND and AGND) be made to the analog ground plane. Power supply pins should be individually decoupled at the pin. The digital circuitry that gets its input from the TMC1175A/1275 should be referred to the system digital ground plane.

**Printed Circuit Board Layout**

Designing with high performance mixed-signal circuits demands printed circuits with ground planes. Wire-wrap is not an option, even for breadboarding. Overall system performance is strongly influenced by the board layout. Capacitive coupling from digital to analog circuits may result in poor A/D conversion. Consider the following suggestions when doing the layout:

1. Keep the critical analog traces (VIN, RT, RB, VR+, VR-) as short as possible and as far as possible from all digital signals. The TMC1175A/1275 should be located near the board edge, close to the analog input connectors.
2. The power plane for the TMC1175A/1275 should be separate from that which supplies the rest of the digital circuitry. A single power plane should be used for all of the VDD pins. If the power supply for the TMC1175A/1275 is the same as that of the system's digital circuitry, power to the TMC1175A/1275 should be decoupled with ferrite beads and 0.1µF capacitors to reduce noise.

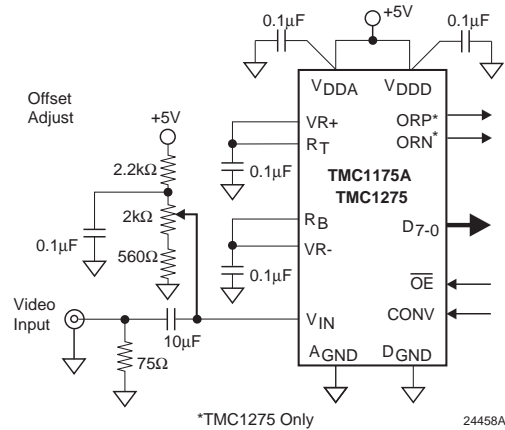

Figure 13. Typical Interface Circuit - Low Cost

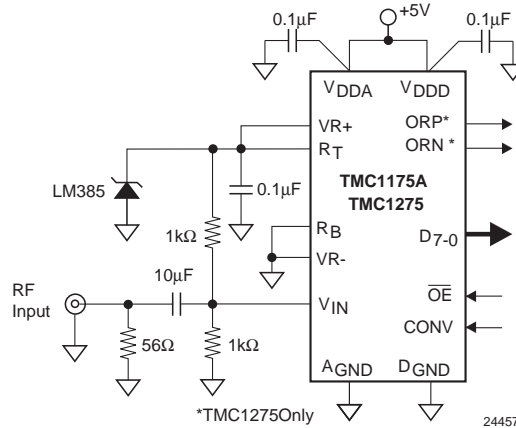

Figure 14. Typical Interface Circuit - Stabilized Reference

3. The ground plane should be solid, not cross-hatched. Connections to the ground plane should have very short leads.
4. Decoupling capacitors should be applied liberally to VDD pins. Remember that not all power supply pins are created equal. They supply different circuits on the integrated circuit, each of which generate varying amounts and types of noise. For best results, use 0.1 $\mu$ F ceramic capacitors. Lead lengths should be minimized. Ceramic chip capacitors are the best choice.
5. If the digital power supply has a dedicated power plane layer, it should not be placed under the TMC1175A/1275, the voltage reference, or the analog inputs. Capacitive coupling of digital power supply noise from this layer to the TMC1175A/1275 and its related analog circuitry can have an adverse effect on performance.
6. CONV should be handled carefully. Jitter and noise on this clock may degrade performance. Terminate the clock line at the CONV input, if required, to eliminate overshoot and ringing.

### Evaluation Board

An evaluation board is available that implements good interface practices and provide a convenient testbed for developing system applications and circuit variations. An on-board D/A converter is provided to reconstruct the digitized signal and to evaluate converter performance.

Contact your sales representative for information.

**Notes:**

**Notes:**



# Mechanical Dimensions

## 24 Lead SOIC (5.4 mm) Package

Symbol	Inches		Millimeters		Notes
	Min.	Max.	Min.	Max.	
A	.067	.075	1.70	1.90	
A1	.004	.012	0.10	0.31	
B	.014	.020	0.36	0.51	
C	.006	.012	0.15	0.30	
D	.587	.610	14.90	15.50	
E	.205	.220	5.20	5.60	
E1	.295	.319	7.50	8.10	
e	.050 BSC		1.27 BSC		
h	.010	.020	0.25	0.50	
L	.016	.050	0.41	1.27	
N	24		24		
$\alpha^\circ$	0	8	0	8	
ccc	-	.004	-	0.10	

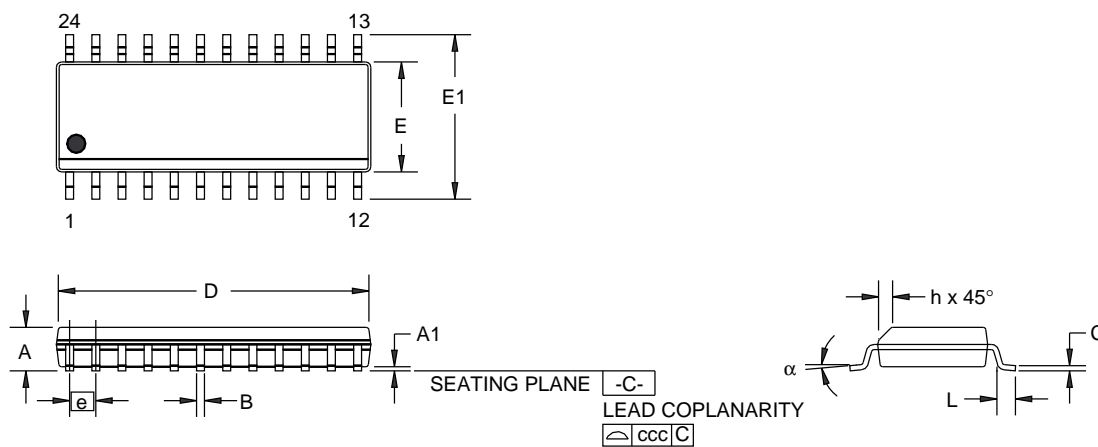

# Mechanical Dimensions (continued)

## 24 Lead Plastic DIP .300" Package

Symbol	Inches		Millimeters		Notes
	Min.	Max.	Min.	Max.	
A	—	.210	—	5.33	
A1	.015	—	.38	—	
A2	.115	.195	2.53	4.95	
B	.014	.022	.36	.56	
B1	.045	.070	1.14	1.78	
C	.008	.015	.20	.38	4
D	1.125	1.275	28.58	32.39	2
D1	.005	—	.13	—	
E	.300	.325	7.62	8.26	
E1	.240	.280	6.10	7.11	2
e	.100 BSC		2.54 BSC		
eB	—	.430	—	10.92	
L	.115	.160	2.92	4.06	
N	24		24		5

**Notes:**

1. Dimensioning and tolerancing per ANSI Y14.5M-1982.
2. "D" and "E1" do not include mold flashing. Mold flash or protrusions shall not exceed .010 inch (0.25mm).
3. Terminal numbers are shown for reference only.
4. "C" dimension does not include solder finish thickness.
5. Symbol "N" is the maximum number of terminals.

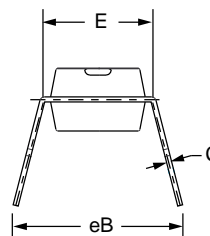
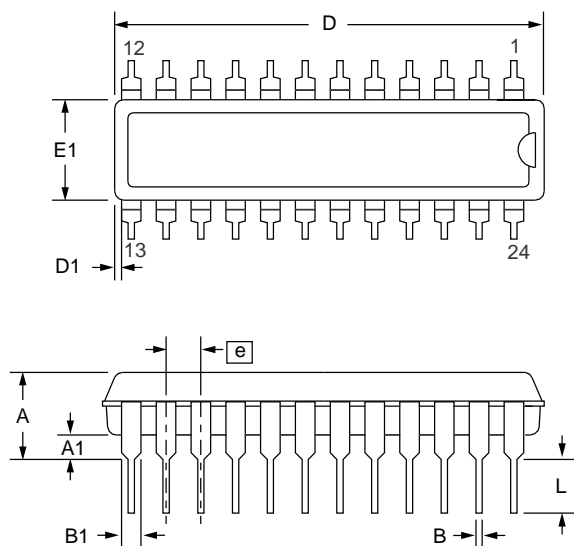

# Mechanical Dimensions (continued)

## 28 Lead PLCC Package

Symbol	Inches		Millimeters		Notes
	Min.	Max.	Min.	Max.	
A	.165	.180	4.19	4.57	
A1	.090	.120	2.29	3.05	
A2	.020	—	.51	—	
B	.013	.021	.33	.53	
B1	.026	.032	.66	.81	
D/E	.485	.495	12.32	12.57	
D1/E1	.450	.456	11.43	11.58	3
D3/E3	.300 BSC		7.62 BSC		
e	.050 BSC		1.27 BSC		
J	.042	.048	1.07	1.22	2
ND/NE	7		7		
N	28		28		
ccc	—	.004	—	0.10	

**Notes:**

1. All dimensions and tolerances conform to ANSI Y14.5M-1982
2. Corner and edge chamfer (J) = 45°
3. Dimension D1 and E1 do not include mold protrusion. Allowable protrusion is .101" (.25mm)

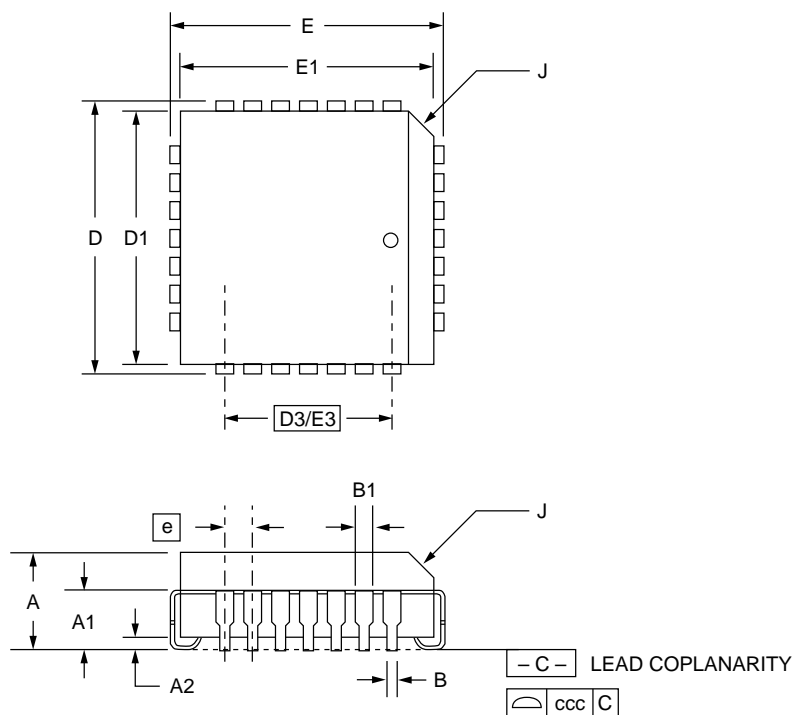

## Ordering Information

Product Number	Conversion Rate	Temperature Range	Screening	Package	Package Marking
TMC1175AM7C20	20 Msps	T <sub>A</sub> = -20°C to 75°C	Commercial	24-Lead SOIC	1175AM7C20
TMC1175AM7C30	30 Msps	T <sub>A</sub> = -20°C to 75°C	Commercial	24-Lead SOIC	1175AM7C30
TMC1175AM7C40	40 Msps	T <sub>A</sub> = -20°C to 75°C	Commercial	24-Lead SOIC	1175AM7C40
TMC1175AM7C50	50 Msps	T <sub>A</sub> = -20°C to 75°C	Commercial	24-Lead SOIC	1175AM7C50
TMC1175AN2C20	20 Msps	T <sub>A</sub> = -20°C to 75°C	Commercial	24-Lead PDIP	1175AN2C20
TMC1175AN2C30	30 Msps	T <sub>A</sub> = -20°C to 75°C	Commercial	24-Lead PDIP	1175AN2C30
TMC1175AN2C40	40 Msps	T <sub>A</sub> = -20°C to 75°C	Commercial	24-Lead PDIP	1175AN2C40
TMC1175AN2C50	50 Msps	T <sub>A</sub> = -20°C to 75°C	Commercial	24-Lead PDIP	1175AN2C50
TMC1175AR3C20	20 Msps	T <sub>A</sub> = -20°C to 75°C	Commercial	28-Lead PLCC	1175AR3C20
TMC1175AR3C30	30 Msps	T <sub>A</sub> = -20°C to 75°C	Commercial	28-Lead PLCC	1175AR3C30
TMC1175AR3C40	40 Msps	T <sub>A</sub> = -20°C to 75°C	Commercial	28-Lead PLCC	1175AR3C40
TMC1175AR3C50	50 Msps	T <sub>A</sub> = -20°C to 75°C	Commercial	28-Lead PLCC	1175AR3C50
TMC1275M7C20	20 Msps	T <sub>A</sub> = -20°C to 75°C	Commercial	24-Lead SOIC	1275M7C20
TMC1275M7C30	30 Msps	T <sub>A</sub> = -20°C to 75°C	Commercial	24-Lead SOIC	1275M7C30
TMC1275M7C40	40 Msps	T <sub>A</sub> = -20°C to 75°C	Commercial	24-Lead SOIC	1275M7C40
TMC1275M7C50	50 Msps	T <sub>A</sub> = -20°C to 75°C	Commercial	24-Lead SOIC	1275M7C50
TMC1275N2C20	20 Msps	T <sub>A</sub> = -20°C to 75°C	Commercial	24-Lead PDIP	1275N2C20
TMC1275N2C30	30 Msps	T <sub>A</sub> = -20°C to 75°C	Commercial	24-Lead PDIP	1275N2C30
TMC1275N2C40	40 Msps	T <sub>A</sub> = -20°C to 75°C	Commercial	24-Lead PDIP	1275N2C40
TMC1275N2C50	50 Msps	T <sub>A</sub> = -20°C to 75°C	Commercial	24-Lead PDIP	1275N2C50
TMC1275R3C20	20 Msps	T <sub>A</sub> = -20°C to 75°C	Commercial	28-Lead PLCC	1275R3C20
TMC1275R3C30	30 Msps	T <sub>A</sub> = -20°C to 75°C	Commercial	28-Lead PLCC	1275R3C30
TMC1275R3C40	40 Msps	T <sub>A</sub> = -20°C to 75°C	Commercial	28-Lead PLCC	1275R3C40
TMC1275R3C50	50 Msps	T <sub>A</sub> = -20°C to 75°C	Commercial	28-Lead PLCC	1275R3C50

The information contained in this data sheet has been carefully compiled; however, it shall not by implication or otherwise become part of the terms and conditions of any subsequent sale. Raytheon's liability shall be determined solely by its standard terms and conditions of sale. No representation as to application or use or that the circuits are either licensed or free from patent infringement is intended or implied. Raytheon reserves the right to change the circuitry and any other data at any time without notice and assumes no liability for errors.

### LIFE SUPPORT POLICY:

Raytheon's products are not designed for use in life support applications, wherein a failure or malfunction of the component can reasonably be expected to result in personal injury. The user of Raytheon components in life support applications assumes all risk of such use and indemnifies Raytheon Company against all damages.

Raytheon Electronics  
Semiconductor Division  
5580 Morehouse Drive  
San Diego CA, 92121  
619.457.1000  
800.722.7074  
Fax 619.455.6314  
applications@lj.sd.ray.com